

PHBN170067-HB

Your investment in lighting will be returned to the bottom line



Product Features

- Dimmable optional
- Perfect disassembling design, can easily disassemble the lamp body, maintenance or installation
- Very high performance thanks to efficient thermal management
- Compatible with smart systems like POE system, Dynaite system,ect

Main application

- Industrial plants
- Stadium
- Warehouse
- Logistics center
- Petrol station

Technical specifications

Product item	PHBN170067-HB	PHBN170067-HB
Installation	Suspension	
Housing color	WH	
Power supply	220-240VAC/50-60Hz	
Watt(W)	100	200
Lumen LED(lm)	10500	21000
System efficacy(lm/w)	82	82
CCT	3000K,4000K	
CRI	80, 90	
SDCM	< 3	
Beam angle(°)	80	80
Lifetime	30,000	
Protection class	IP20	
Material	Alumimun	



Product dimension(mm)

PHBN170067-HB-1

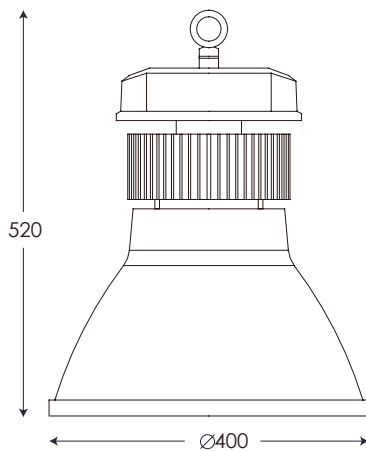

PHBN170067-HB-2

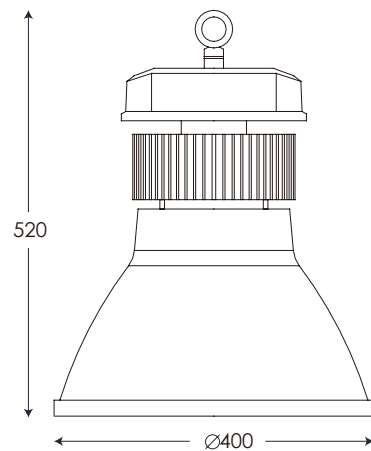

Photometric Data

PHBN170067-HB-1

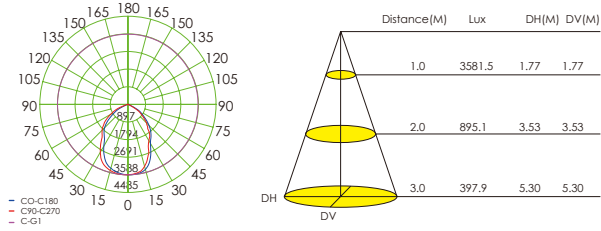

Order info	Driver output	Beam angle	CCT
PHBN170067-HB-1	2000mA	80	3000k/4000k
PHBN170067-HB-2	5000mA	80	3000k/4000k